

425649.002

**KNOTT**

## Adjustment instructions

Braking system

These instructions describe the adjustment of  
KNOTT wheel brakes on trailers with overrun brakes

- Step 1:** Jack up the trailer according to the vehicle manufacturer's instructions
- Step 2:** Release parking brake
- Step 3:** Loosen brake linkage [6] on transmission lever [4] of the overrun device several turns and check if the drawtube [5] is fully extended
- Step 4:** Turn the wheel in the **FORWARD** direction of rotation by hand while tightening the adjusting screw [9] (clockwise rotation) until the wheel can just no longer be turned by hand.



Adjustmentbolt – wrench size SW17

- Step 5:** Then loosen the adjusting screw [9] by ½ turn (counterclockwise rotation) until the wheel runs freely again

---

Herausgeber **KNOTT GmbH** · Erstellt jst 2023-03-28 – aktuelle Version 01, 28. März 2023 / jst

Seite 1 von 4

425649.002



## Adjustment instructions

### Braking system

- Step 6:** Carry out adjustment on all other wheel brakes in the same way.
- Step 7:** Checking or setting the balancer bar(s) [7 + 8] perpendicular to the longitudinal axis of the brake linkage [6].
- Step 8:** Adjust the brake linkage [6] on the overrun device so that it is free of play, but without pretension. The transmission lever must be in contact with the drawtube [5].

**The spreadlever-box in the brake must not be pretensioned!**

- Step 9:** Repeated actuation of the handbrake-lever [3] with slight pressure
- Step 10:** Check that brake linkage has no play, adjust again if necessary.
- Step 11:** Countering the brake linkage on the transmission lever [4] of the overrun device
- Step 12:** Checking the handbrake lever position after engaging the parking brake  
The handbrake lever must overcome the dead center.

Note: These instructions are also available as a video on the Internet at the following link:

<https://www.youtube.com/watch?v=oo9xiiz8Kb0>

or by searching for "KNOTT brake adjustment" on YouTube

[KNOTT Bremse richtig einstellen - YouTube](#)

# 425649.002

## Adjustment instructions



### Braking system

- [1] Abreißseil
- [2] Zugkuglkupplung
- [3] Handbremshebel
- [4] Umlenkhebel
- [5] Zugstange mit Faltenbalg
- [6] Bremsgestänge
- [7] Ausgleichswaage (Tandem)
- [8] Ausgleichswaage (Einachser)
- [9] Einstellschraube

Schlüsselweite Einstellschraube [9]

Bremsengröße	Schlüsselweite
160x35 / 200x50	SW 17
250x40 / 250x50	SW 19
300x60	SW 24

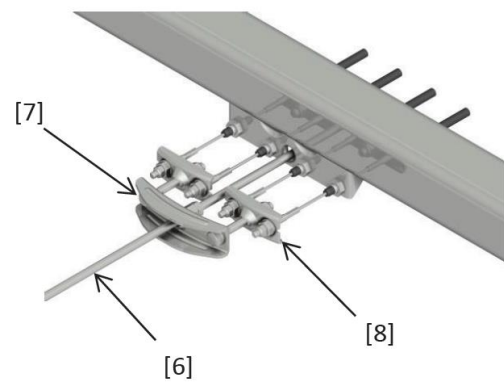
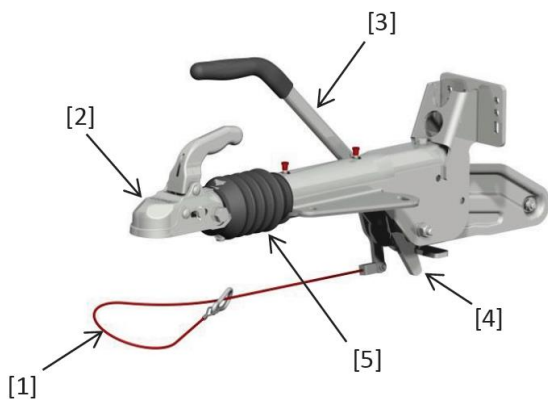

# 425649.002



## Adjustment instructions

### Braking system

Version	Ä.-Nr.	Änderungsbeschreibung	Datum	Verantw.
V01	-----	Original version	2023-03-28	J. Strasser